

EICP Compact Switching Hubs



- Industrial temperature range (0°C to +60°C)
- Compact size
- Plug-and-Play (PnP)
- 10BASE-T/100BASE-TX/100BASE-FX compliant
- Shielded RJ-45 connectors or SC/ST-style fibre optic connectors
- Auto-negotiated data rate, duplex, and flow control on twisted-pair ports

- Auto-MDIX on twisted-pair ports
- Powered from an unregulated DC power source (10–36 V) or from an AC power source (8–24 V, 47–63 Hz). Power is provided through a quick-disconnect terminal strip.
- Multimode or single-mode fibre
- Full- or half-duplex operation on twisted-pair ports
- Provision for redundant power connections
- LEDs for link/activity/data rate and power
- Easy panel or DIN-rail mounted installation
- Industrial environment EMC compatible
- UL 508 Listed, Industrial Control Equipment
- C-UL Listed, CSA 22.2 No. 14-M91, Industrial Control Equipment
- CE Mark
- RoHS compliant

PRODUCT OVERVIEW

EICP switches, supporting both twisted-pair and fibre optics, fill the need for those industrial and commercial applications requiring a small footprint and a temperature range between 0°C to +60°C.

Each unit segments the Ethernet LAN into multiple collision domains, acting as a “bridge” between data links to create a larger network diameter than possible with repeating hubs. Each copper port automatically negotiates data rate, duplex, and flow control.

The switch learns port assignments by reading Ethernet frames and logging source addresses into a table which can hold over 4,000 addresses. With this information, it improves throughput by restricting traffic to only those ports party to a data exchange — while other data is simultaneously exchanged on other ports. Store-and-forward operation of frames is implemented using 256 kB of built-in memory.

Only standard straight-through cables are needed to connect copper ports to NIMs or another hub.

Eight (MDIX) copper ports are available on the EICP9-100T for attaching local devices with the ninth copper port being used as an uplink port. In addition to one power LED, each port has an LED showing link/activity/data rate by colour: green for 100 Mbps and yellow for 10 Mbps. Flashing indicates port activity.

Each unit accepts wide-range, low-voltage AC or DC power and has terminals for redundant power.

The unit is shipped with a DIN-rail clip installed. If direct mounting to a sub-panel is desired, an optional panel mounting bracket, shipped with the product, can be installed after removing the DIN-rail clip.

Mechanical

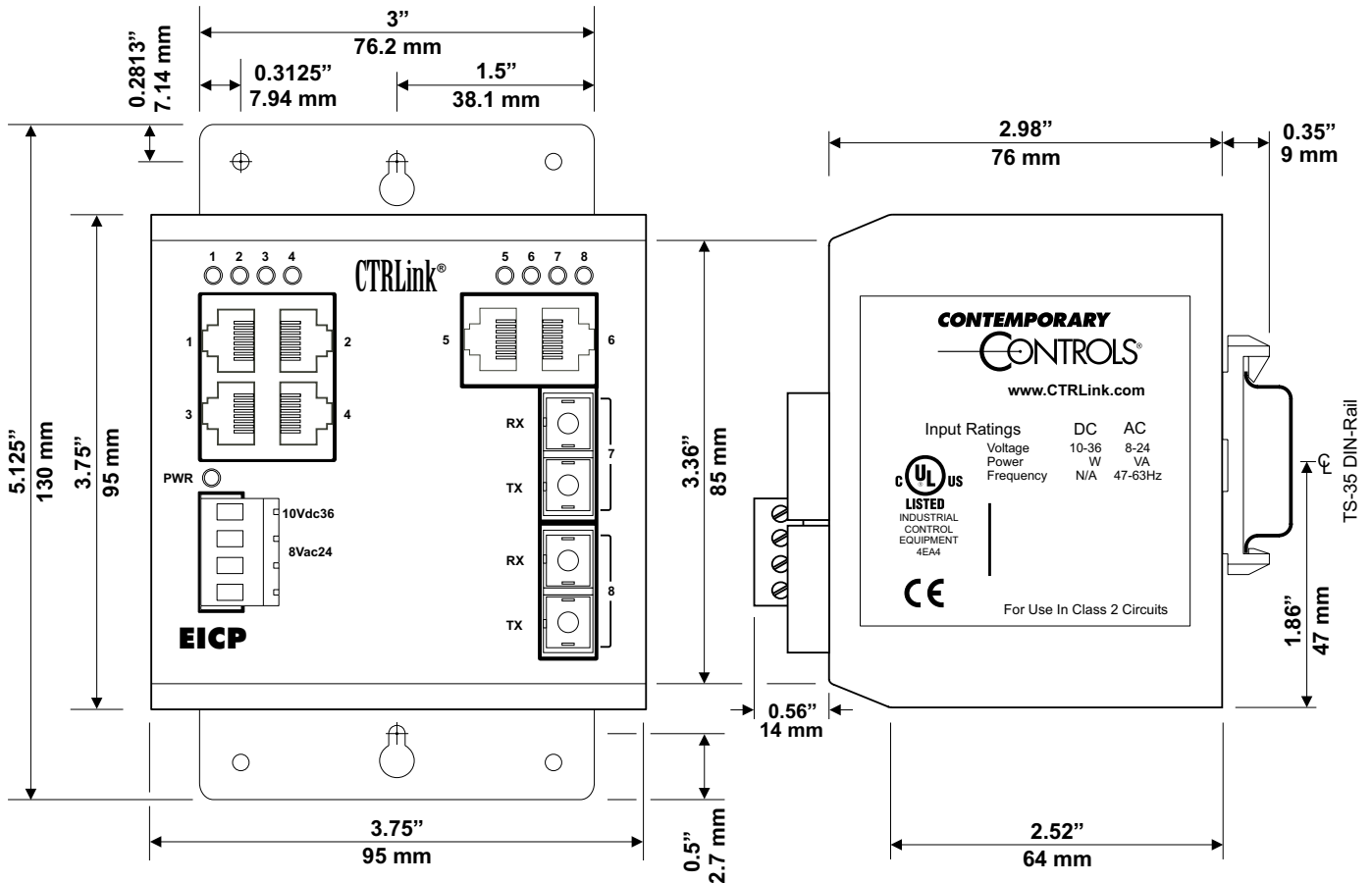

Optional Panel Mounting Bracket (depicted above) is included.

Standard DIN-Rail Mounting Bracket (depicted above) is pre-attached.

Power Diagrams

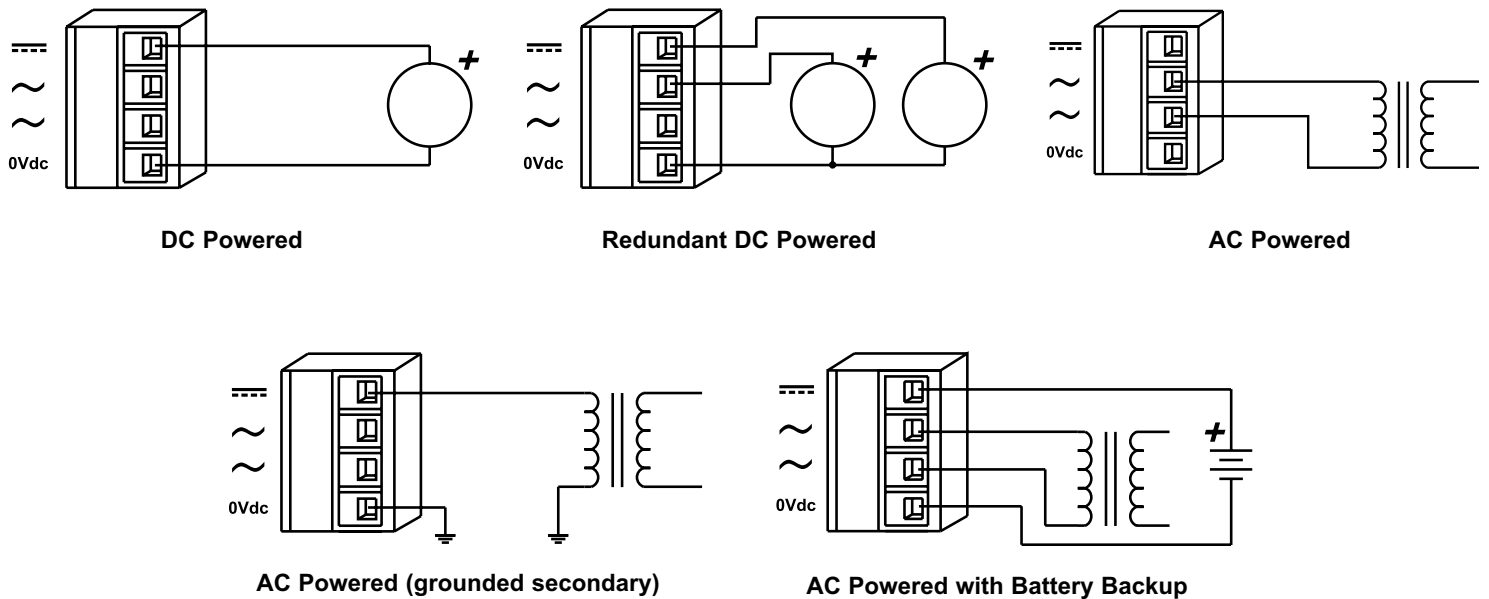

Specifications

Electrical	DC	AC
Input voltage	10–36 Volts	8–24 Volts
Input power	6 W (EICP9-100T)	6 VA (EICP9-100T)
	10 W (EICP9-100T/FT, FC, FCS)	10 VA (EICP9-100T/FT, FC, FCS)
	6 W (EICP8-100T)	6 VA (EICP8-100T)
	10 W (EICP8-100T/FT, FC, FCS)	10 VA (EICP8-100T/FT, FC, FCS)
Input frequency	N/A	47–63 Hz

Environmental

Operating temperature	0°C to +60°C
Storage temperature	–40°C to +85°C
Relative humidity	10–95% non-condensing
Protection	IP30

Functionality

Standards	IEEE 802.3
Process type	Store-and-Forward

Ports

	Copper twisted-pair	Fibre 1300 nm
Number of ports	9, 8 or 6	0, 1 or 2
Interface	10BASE-T/100BASE-TX 10/100 Mbps Auto-negotiated data rate, flow control, full- or half-duplex mode and Auto-MDIX cable connection	100BASE-FX 100 Mbps Full-duplex
Connectors	Shielded RJ-45	SC (on multimode or single-mode models) ST (only on multimode models)
Maximum segment length	100 m	2 km (multimode), optical budget: 13 dB 15 km (single-mode), optical budget: 19 dB
LED signal indicators	Link LED: Yellow — 10 Mbps Green — 100 Mbps Green Flashing — Activity	Green — 100 Mbps link Flashing — Activity
LED power indicator	Green	
Flow control	Half-duplex (backpressure)	Full-duplex (PAUSE)
Aging	300 seconds	

RJ-45 Pin Assignments

MDI-X[†] 10BASE-T/100BASE-TX

RJ-45	Usage
1	TD+
2	TD–
3	RD+
4	Not Used
5	Not Used
6	RD–
7	Not Used
8	Not Used

[†] Ports normally assume the internal crossover function, but will automatically adapt to connected devices.

Electromagnetic Compatibility

Standard	Test Method	Description	Test Levels
EN 55024	EN 61000-4-2	Electrostatic Discharge	6 kV contact
EN 55024	EN 61000-4-3	Radiated Immunity	10 V/m, 80 MHz to 1 GHz
EN 55024	EN 61000-4-4	Fast Transient Burst	1 kV clamp & 2 kV direct
EN 55024	EN 61000-4-5	Voltage Surge	1 kV L-L & 2 kV L-Earth
EN 55024	EN 61000-4-6	Conducted Immunity	10 Volts (rms)
EN 55024	EN 61000-4-11	Voltage Dips & Interruptions	1 Line Cycle, 1 to 5 s @ 100% dip
EN 55022	CISPR 22	Radiated Emissions	Class B
EN 55022	CISPR 22	Conducted Emissions	Class B
CFR 47, Part 15	ANSI C63.4	Radiated Emissions	Class A

Ordering Information**Copper Only**

Model	Description
EICP9-100T	Nine-port 10BASE-T/100BASE-TX compact switch

Fibre and Copper

EICP9-100T/FC	Four-port 100BASE-TX/one-port 100BASE-FX (multimode) switch, SC connectors
EICP9-100T/FT	Four-port 100BASE-TX/one-port 100BASE-FX (multimode) switch, ST connectors
EICP9-100T/FCS	Four-port 100BASE-TX/one-port 100BASE-FX (single-mode) switch, SC connectors
EICP8-100T/FC	Six-port 100BASE-TX/two-port 100BASE-FX (multimode) switch, SC connectors
EICP8-100T/FT	Six-port 100BASE-TX/two-port 100BASE-FX (multimode) switch, ST connectors
EICP8-100T/FCS	Six-port 100BASE-TX/two-port 100BASE-FX (single-mode) switch, SC connectors

Accessories

Model	Description
AI-XFMR	Wall-mount plug-in transformer, 120 VAC input/24 VAC output (nominal values)
AI-XFMR-E	Wall-mount plug-in transformer, 230 VAC input/24 VAC output (nominal values)

Contemporary Controls, ARC Control, ARC DETECT, EXTEND-A-BUS and CTRLink are registered trademarks or trademarks of Contemporary Control Systems, Inc. Specifications are subject to change without notice. Other product names may be trademarks or registered trademarks of their respective companies.

© Copyright 2007 Contemporary Control Systems, Inc.

CONTEMPORARY CONTROLS®
www.ccontrols.com

Contemporary Control Systems, Inc.
2431 Curtiss Street
Downers Grove, Illinois 60515 USA

Telephone (630) 963-7070
Fax (630) 963-0109